

11004 DOG SPRING RIDER



TECHNICAL DATA:

Device dimensions:	0,34m x 0,97m
Device height:	~0,82m
Minimum space:	3,97 x 3,34m
Critical fall height:	0,60m
Falling area:	64,56m ²
Depth of foundations:	-0,60m

Top view with falling area

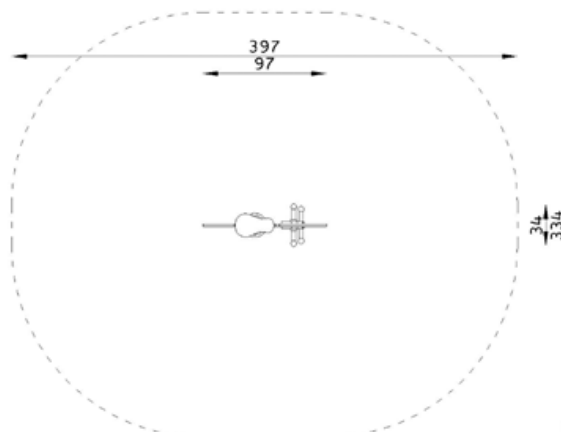

The device according to EN 1176-1:2012
Playground equipment and surfacing – Part 1:
General safety requirements and test methods.

Safety surfaces:

- turf/topsoil, sand, gravel, bark, synthetic surface
- minimal thickness for loose particulate materials 200+100mm
- synthetic surface according to critical fall height

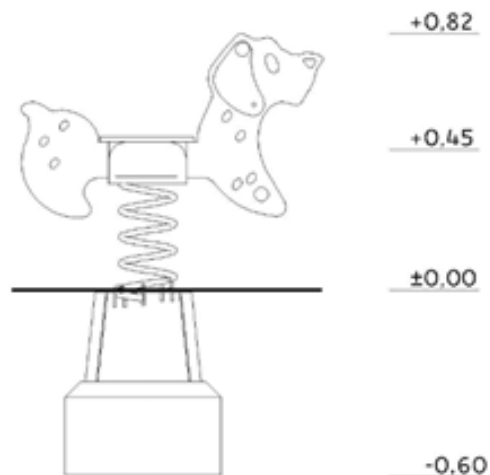

MATERIALS:

Decorative elements:	HDPE sheet
Handles, leg supports:	plastic
Steel elements:	galvanized steel, powder coated
Spring:	spring steel, galvanized and powder coated in red
Caps:	plastic
Foundation base:	steel structure
Foundations:	concrete class min. C12/15



SATERNUS DISTRIBUTION Sp. z o.o. sp.k.
ul. Nowa 32
41-500 Chorzów, Poland

Certificate beholder:
Producer:
Distributor:

GRUPA SATERNUS Sp. z o.o. S. K. A. reserves all rights to protect copyright under the Act of February 4, 1994 on Copyright and Related Rights (Journal of Laws No. 28, item 83), and in particular Art. 78 and 79 of this Law.

GRUPA SATERNUS Sp. z o.o. S. K. A.
Saternus Production Sp. z o.o. sp. k.
Saternus Distribution Sp. z o.o. sp. k.